

ANY REPRODUCTION IN PART OR AS A WHOLE WITHOUT THE WRITTEN PERMISSION OF MUSCLE MACHINE AB IS PROHIBITED.

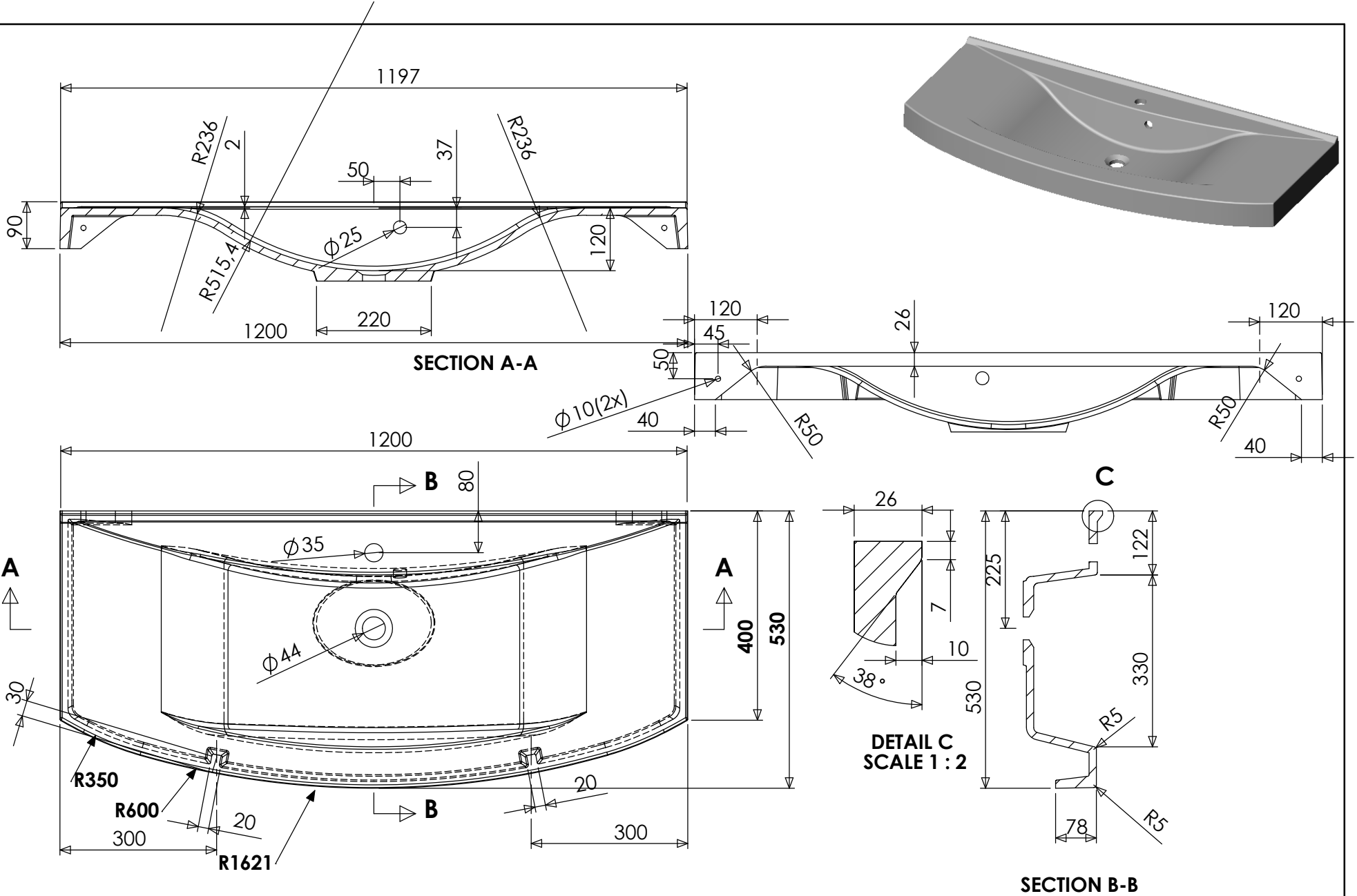

Tolerance length	+3/-0 mm	DALLE	DR	040624	SCALE-1:10	Marmite	1200C
Tolerance length granite	+1,5/-1,5 mm	Muscle Machine AB		marmite [®]	MARMITE FRIDA 1200C 1198121xx		
Tolerance taphole location	+1/-1 mm						
Variation overflowhole location	+1/-1 mm						1:5
Tolerance plane bending	+1,5/-1,5 mm						