

PROPRIETARY AND CONFIDENTIAL
 THE INFORMATION CONTAINED IN THIS DRAWING IS THE SOLE PROPERTY OF MUSCLE MACHINE AB.
 ANY REPRODUCTION IN PART OR AS A WHOLE WITHOUT THE WRITTEN PERMISSION OF MUSCLE MACHINE AB IS PROHIBITED.

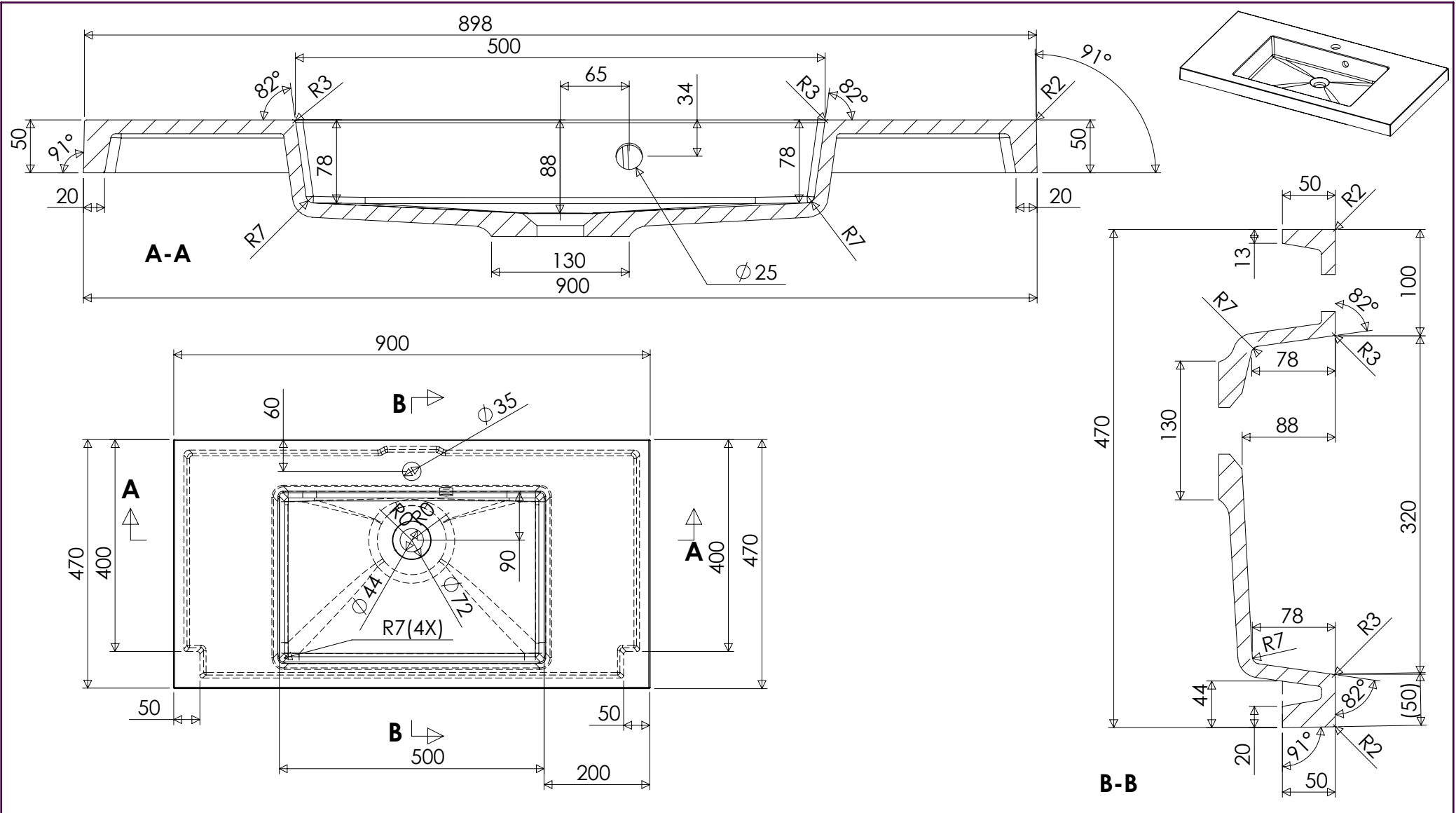

Tolerance length	+3/-0 mm	Ritad	DR	Konstr	DR	Skala	1:10	090617	MARMITE	Filnamn	6010650911	
Tolerance length granite	+1,5/-1,5 mm	<div style="display: flex; justify-content: space-around; align-items: center;"> <div style="text-align: center;">  </div> <div style="text-align: center;"> <p>MARTA 900C</p> <p>6010650911xx</p> </div> </div>								ErsÖfter		
Tolerance taphole location	+3/-3 mm									Revision		
Tolerance overflowhole location	+3/-3 mm									Ritning		
Tolerance plane bending	+1,5/-1,5 mm									1:6		