

PROPRIETARY AND CONFIDENTIAL
 THE INFORMATION CONTAINED IN THIS DRAWING IS THE SOLE PROPERTY OF MUSCLE MACHINE AB.
 ANY REPRODUCTION IN PART OR AS A WHOLE WITHOUT THE WRITTEN PERMISSION OF MUSCLE MACHINE AB IS PROHIBITED.

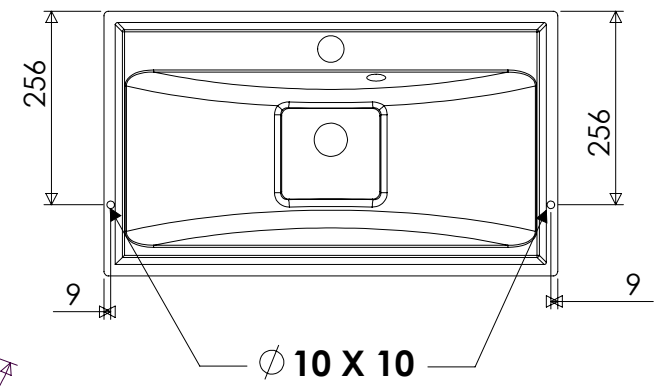
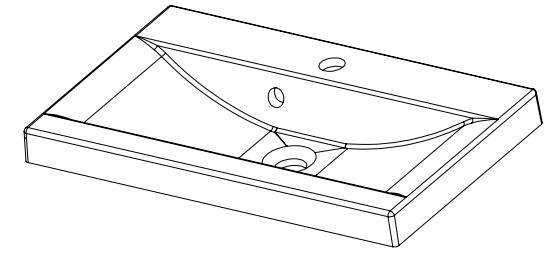
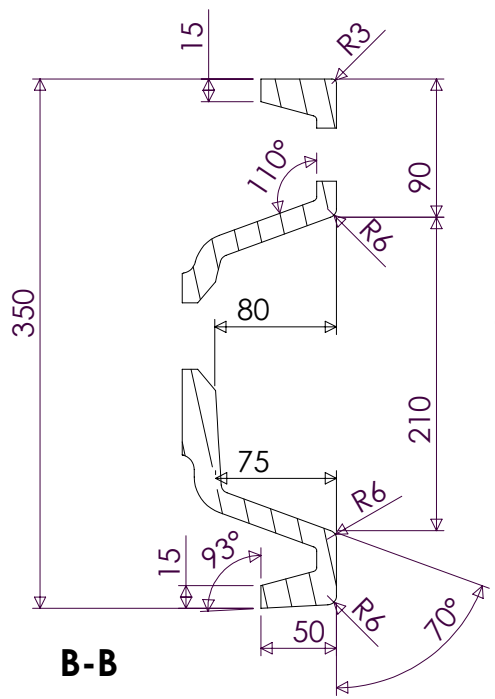
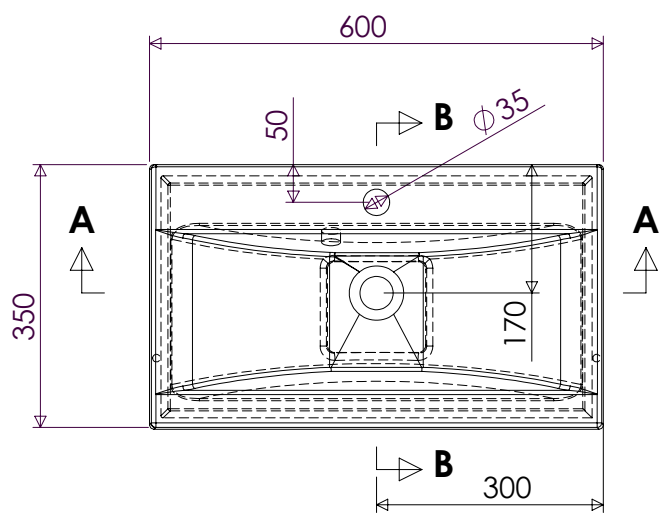
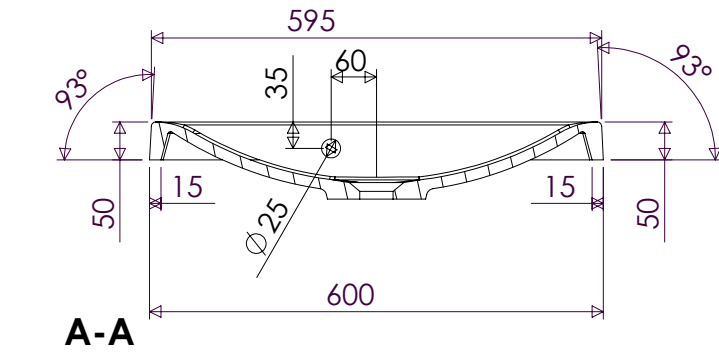

Tolerance length	+3/-0 mm	Ritad	DR	Konstr	DR	Skala	1:20	090105	MARMITE	Filenamn	6010550611											
Tolerance length granite	+1,5/-1,5 mm									SELINA 600C 6010550611 xx			Ersätter									
Tolerance taphole location	+3/-3 mm												Revision		Revdatt							
Tolerance overflowhole location	+3/-3 mm												Ritning					1:6				
Tolerance plane bending	+1,5/-1,5 mm																					